

TRUCK AND BUS TYRES

AEOLUS-TYRES.COM

AEOLUS

NO MATTER WHAT

NEO SERIES

04 About Aeolus Tyres

05 Hence Aeolus

06 NEO Series

08 Aeolus team

34 Steering axle patterns and sizes

36 Drive axle patterns and sizes

38 Trailer patterns and sizes

40 All positions patterns and sizes

42 Technical details

50 Regrooving

09 NEO Allroads

NEO Allroads S
NEO Allroads S+
NEO Allroads D
NEO Allroads D+
NEO Allroads T2

17 NEO Fuel

NEO Fuel S
NEO Fuel S+
NEO Fuel D
NEO Fuel T+



23 NEO Construct

NEO Construct G
NEO Construct D

27 NEO Winter

NEO Winter S
NEO Winter D

31 NEO Urban

NEO Urban G



Ever since entering the European market (2004), we have been supplying tyres that offer the highest quality in their respective product segments. Tyres designed in accordance with European quality norms and ideal for the most demanding circumstances. We use high performance and the best price to guarantee our customers a low price per kilometre. **Aeolus. No matter what.**



We decided to take over Pirelli in 2017 in order to reinforce our position in the international tyre market. We thought it would be a good idea to harness the strengths of a large Asian brand with those of a renowned European brand. A smart move because it has put us in an even better position to meet the needs of the tyre market. A useful move because it has given a massive boost to our logistical & technological developments.

AEOLUS TYRES

Total supplier

A tyre brand supplies tyres. Tyres in all sizes, with every pattern. Our products can be used anywhere for a variety of purposes. Truck and trailer tyres, bus tyres, OTR tyres, agricultural tyres, machine tyres, on and off-road tyres... you name it. This means you can do whatever you need, in all circumstances. Always.

Earthmoving

Robust, top quality and hard-wearing: essential characteristics for tyres also those used during earth-moving activities. These tyres come with an hour-based guarantee, which (depending on the vehicle and use) guarantees a minimum number of operating hours. We also offer the market a comprehensive range, which is capable of meeting all customer needs.

Our range of sizes and patterns, as well as our great price/quality ratio, takes care of the rest.

Agriculture

The agricultural sector is always on the move, which means so are we. It is nice to be a front-runner, when it comes to developing a wide range of tyres (specials) with strong casings and ingenious patterns, but nothing more than that. That is why we always examine what is going on around us: looking for opportunities and chasing innovations & developments. Because being a front-runner is about being smart. And you are smart if you remain on your toes and know what is happening in your surroundings. This is something we have always known.



**Truck
Earthmoving
Agriculture**

Our tyres are for your benefit. For experts that know how rough outdoor terrains can be; for specialists familiar with the pain that accompanies bad roads. Day in, day out. That is why we develop the best performing, strongest and most innovative tyres. But also because we are able to. And when doing so, only the best is good enough. In a way, we see tyre patterns as the noise produced by a Harley Davidson. So stimulate, challenge or provoke us. We will do anything to achieve our ultimate goal: tyres for all weather conditions, all distances and all surfaces. **Aeolus. No matter what.**

NO MATTER WHAT



Quality

We develop and produce tyres in accordance with the international norms of renowned institutes and certifications. Our casing guarantee, as well as our partnership with Pirelli, guarantees high basic quality.



Availability

Just about all sizes and patterns are available from stock, which means our products are very easy to obtain. For instance, we always have 30,000 tyres in stock at our four different warehouses.



Price

With core competencies like quality, sustainability and quality, we are the leading alternative for renowned premium brands. The best price per kilometre takes care of the rest.



Sustainability

We continuously invest in environment-friendly production and comply with the ambitious norms of the 'Waste Zero Emission' label and the REACH programme.



Aeolus Breakdown Service (24/7)

Back on the road quickly after a puncture. Our Breakdown service will help you to get back on the road as soon as possible: 24 hours a day, 365 days a year, all throughout Europe. We help you to minimise lost time.



Service

Instead of empty promises, Aeolus offers proven quality: ranging from our qualified and helpful sales and service team, to our Aeolus Breakdown service all throughout Europe.



Wide range

We have a very wide range of products, which offers solutions for almost all purposes involving trucks, earth-moving machines, forestry & agricultural machines as well as special vehicles.



Research & development

Together with Pirelli, our engineers and technicians are always on the look-out for new ways to improve the tyres we offer, so they continue to meet the needs of the market.



Aeolus Casing Management

Environment-friendliness and sustainability pay dividends for transporters: casings that are suitable for tread renewal are purchased and useless casings are disposed of in accordance with applicable norms.

NEO SERIES

THE ULTIMATE TRUCK TYRE

The NEO series: produced in accordance with the latest technological developments and compliant with the strict needs and preferences of European users. Tyres that are perfectly in keeping with our ambition; to position Aeolus as a top tyre brand all across the globe. A series based on the perfect balance between research, design & technology.

How? By implementing the SATT casing structure and optimising rubber compounds: a great piece of innovation that allows kilometrages to be improved by 25%. Our partnership with Pirelli has been extremely valuable and given the NEO series a huge boost in the tyre market. The Ultimate Truck Tyre.

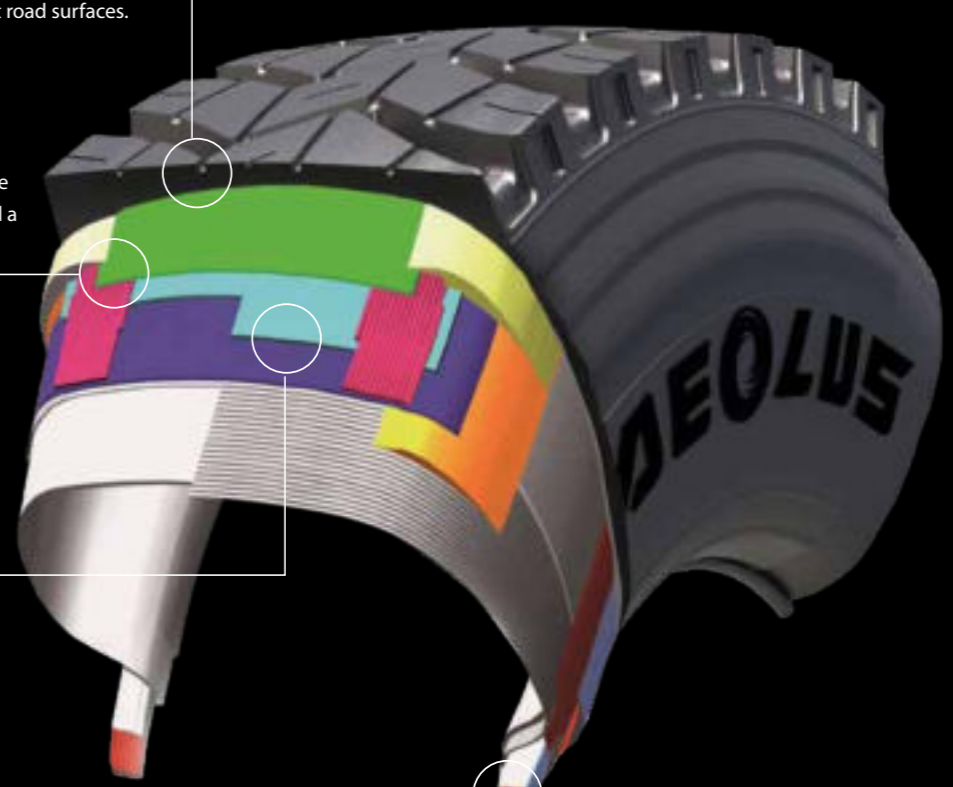

DLT/HSCC rubber compound
European rubber compound with high silicone content, for high kilometrage and better grip on wet road surfaces.

SATT casing structure
Patented European 'SATT' casing design. The 3SB casing ensures uniform wear & tear and a long life-span.

FRC
Extremely strong 'Full Penetration' structure of belt layers, which prevents casing fatigue and offers excellent protection against punctures.

HBW
Patented hexagonal bead wire. Offers better driving comfort and makes the tyre easier to mount.

The NEO series are manufactured under a patent and know how license from **Pirelli Tyre**

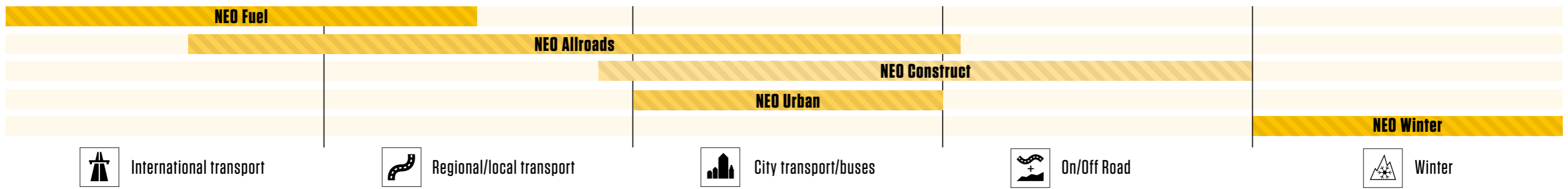



AEOLUS TEAM EUROPE

A top quality team is needed when developing and producing top quality tyres.

Thankfully, we already have such a team.

It's also good to know that our leading position is allowing us to attract the best people: professionals with the required expertise; people that value personal attention and pleasant customer contact.

Visit our website: www.aeolus-tyres.com

NEO ALLROADS

FIT FOR USAGE UNDER EVERY CONDITION,
ON ALL ROADS



The NEO series are manufactured under a patent and know how license from Pirelli Tyre

AEOLUS

NO MATTER WHAT

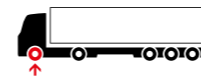
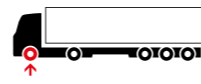

NEO ALLROADS S

- Suitable for Euro 6 legislation (High Load)
- Long life-span thanks to extra wide and extra deep pattern
- Safe driving and braking thanks to intelligent pattern with 4 Z-shaped longitudinal grooves
- Perfect handling on dry and wet surfaces thanks to refined pattern structure
- Noise-friendly due to optimised pattern design
- Ingenious rubber mix ensures balanced heat control
- Resistant against stone build-up due to interchanging pattern grooves

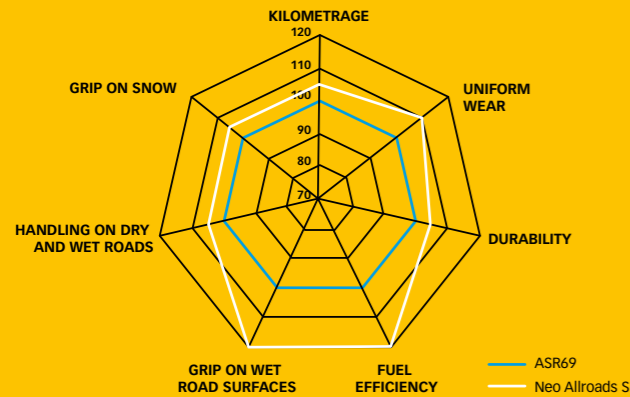

NEO ALLROADS S+

- Long life-span due to extra wide and extra deep pattern
- Safe driving and braking thanks to intelligent pattern with 4 Z-shaped longitudinal grooves
- Perfect handling on dry and wet surfaces thanks to refined pattern structure
- Resistant against stone build-up due to interchanging pattern grooves
- Extra belt layer reinforces casing and improves re-profiling
- Long life-span thanks to extra anti-wear layer in tread compound

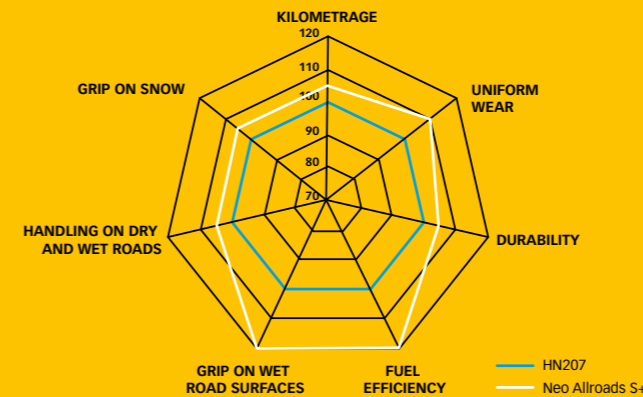

Size	L/S Index	TL/TT	M+S				DB	Class	Available
205/75R17.5	124/122M	TL	M+S						2020
215/75R17.5	126/124M	TL	M+S		D	C	73		Immediately
225/75R17.5	129/127M	TL	M+S						2020
235/75R17.5	132/130M	TL	M+S		D	C	73		Immediately
245/70R17.5	136/134M	TL	M+S		D	C	73		Immediately
265/70R19.5	140/138M	TL	M+S						2020
285/70R19.5	145/143M (146/144L)	TL	M+S		C	C	73		Immediately
295/60R22.5	149/146L (150/147K)	TL	M+S						2020
295/80R22.5	154/149M	TL	M+S		C	C	73		Immediately
315/70R22.5	156/150L (154/150M)	TL	M+S		B	C	73		Immediately
315/80R22.5	158/150L (154/150M)	TL	M+S		C	C	73		Immediately

Size	L/S Index	TL/TT	M+S				DB	Class	Available
385/55R22.5	160K (158L)	TL	M+S		B	B	72		Immediately
385/65R22.5	164K (158L)	TL	M+S		B	A	73		Immediately

NEO Allroads in the spotlight:

Check out the NEO-series in at www.aeolus-tyres.com

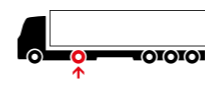

NEO ALLROADS D

- Suitable for regional distribution traffic
- High traction thanks to extra deep grooves with pattern featuring block design
- Pattern featuring inter-connected blocks extends life-span
- Extra quiet and comfortable thanks to sophisticated a-symmetrical block design
- Uniform wear thanks to reinforced shoulder design
- Extra belt layer reinforces casing and improves re-profiling
- Anti-wear layer in tread compound improves economy, noise and kilometrage

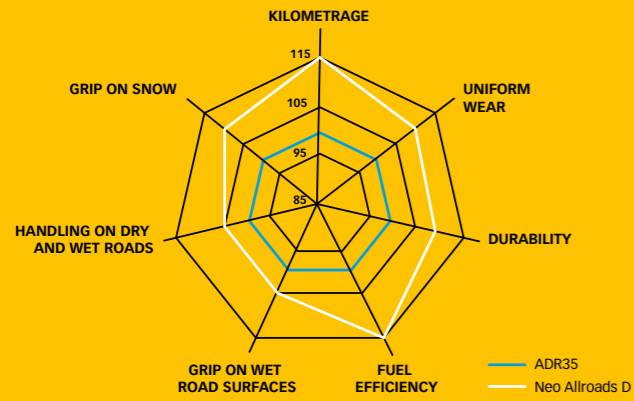

NEO ALLROADS D+

- Excellent life-span thanks to wider directional pattern design with deeper grooves
- Perfect handling on dry and wet surfaces thanks to refined pattern structure (3D sipes)
- Extra belt layer (FRC) reinforces casing, improves re-profiling and enables re-profiling
- Lasting high traction thanks to special groove design (sipes)
- Uniform wear thanks to reinforced shoulder design (RSR)
- Long life-span thanks to extra anti-wear layer in tread compound and special groove design (sipes)

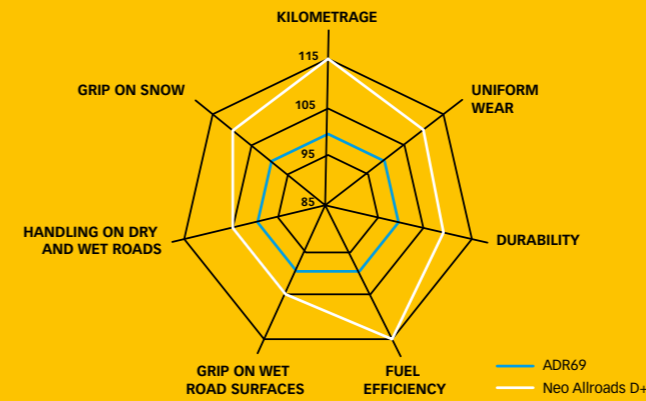

012

013

Size	L/S Index	TL/TT	M+S				DB	Class	Available
205/75R17.5	124/122M	TL	M+S						2020
215/75R17.5	126/124M	TL	M+S		E	D	73		Immediately
225/75R17.5	129/127M	TL	M+S						2020
235/75R17.5	132/130M	TL	M+S		C	D	73		Immediately
245/70R17.5	136/134M	TL	M+S						2020
265/70R19.5	140/138M	TL	M+S		C	D	73		Immediately
285/70R19.5	146/144L (145/143M)	TL	M+S		C	C	73		Immediately

Size	L/S Index	TL/TT	M+S				DB	Class	Available
295/60R22.5	150/147K (149/146L)	TL	M+S		D	B	73		Immediately
295/80R22.5	152/148M	TL	M+S		D	B	73		Immediately
315/60R22.5	152/148L	TL	M+S		D	B	73		Immediately
315/70R22.5	154/150L (152/148M)	TL	M+S		C	B	73		Immediately
315/80R22.5	156/150L (154/150M)	TL	M+S		D	B	73		Immediately

NEO Allroads in the spotlight:

Check out the NEO-series in at www.aeolus-tyres.com

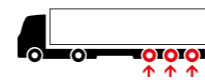

NEO ALLROADS T2



- Flatbed trailer tyre suitable for heavy loads
- Effective handling thanks to intelligent pattern with 4 Z-shaped longitudinal grooves
- Extra quiet and comfortable thanks to sophisticated a-symmetrical block design
- Resistant against stone build-up due to interchanging pattern grooves
- Uniform wear thanks to reinforced shoulder design
- Tread compound for low rolling resistance and effective heat discharge

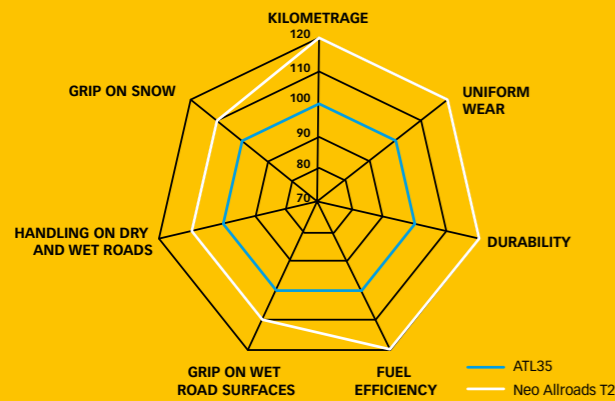

NEO ALLROADS T2



- Long life-span due to extra wide and extra deep pattern
- Effective handling thanks to intelligent pattern with 4 Z-shaped longitudinal grooves
- Extra quiet and comfortable thanks to sophisticated a-symmetrical block design
- Resistant against stone build-up due to interchanging pattern grooves
- Uniform wear thanks to reinforced shoulder design (RSR)
- Tread compound (DLT/HSCC) for low rolling resistance and effective heat discharge

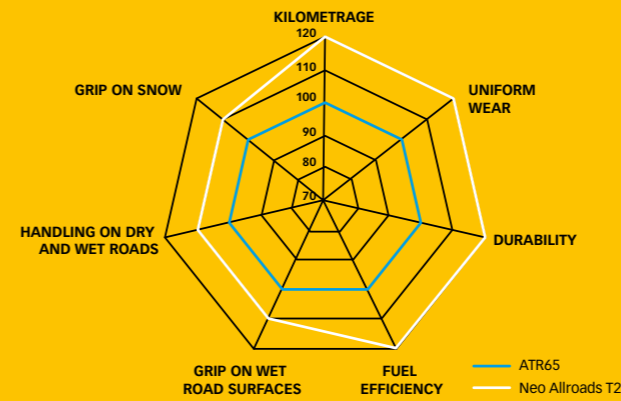

AVAILABLE SOON

014

015

Size	L/S Index	TL/TT	M+S				DB	Class	Available
205/65R17.5	129/127J (132/132F)	TL	M+S		C	C	73		2020
215/75R17.5	135/133J	TL	M+S		C	C	73		Immediately
235/75R17.5	143/141J (144/144F)	TL	M+S		C	C	73		Immediately
245/70R17.5	143/141J (146/146F)	TL	M+S		C	C	73		Immediately
265/70R19.5	143/141J (146F)	TL	M+S		C	C	73		Immediately

Size	L/S Index	TL/TT	M+S				DB	Class	Available
285/70R19.5	150/148J	TL	M+S		C	C	71		Immediately
385/55R22.5	160K (158L)	TL	M+S		B	C	73		Immediately
385/65R22.5	164K (158L)	TL	M+S		B	C	73		Immediately
425/65R22.5	165K	TL	M+S		C	C	71		Immediately
445/65R22.5	169K	TL	M+S		C	C	71		Immediately

Aeolus AR28

THE ULTIMATE HEAVY DUTY TYRE

NO MATTER WHAT.

ROBUST CASING STRUCTURE

SYMMETRICAL BLOCK PATTERN

SPECIAL RUBBER COMPOUND TECHNOLOGY

NEW!

AR28+ AR28



Size	L/S Index	TRA Code	Rim	Dimensions		Pattern depth(mm)	Air pressure (bar)
				Width	Diameter		
385/95R25	170F	E-2	10.00/1.5	389	1363	24	9,00
445/95R25	174F	E-2	11.25/2.0	444	1486	26	9,00

AEOLUS-TYRES.COM

NEO Series - The Ultimate Truck Tyre

NEO Fuel

NEO FUEL

LONG DISTANCE, LESS FUEL

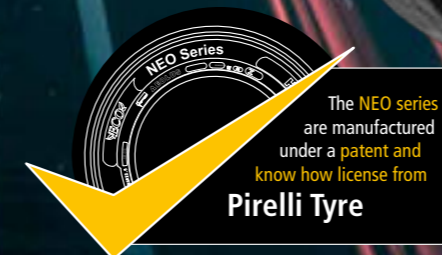

AEOLUS

NO MATTER WHAT

017

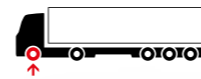
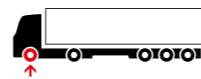

NEO FUEL S

- Suitable for Euro 6 legislation (High Load)
- Water discharge and handling thanks to pattern with connected blocks and 4 longitudinal grooves
- Temperature control at high speeds thanks to special groove design (sipes)
- Long life-span due to Z-shaped asymmetrical pattern that prevents stone build-up
- Anti-wear layer in tread compound improves fuel economy, kilometrage and life-span
- Full multi-layer structure makes casing strong and suitable for regrooving
- Uniform wear thanks to reinforced shoulder design

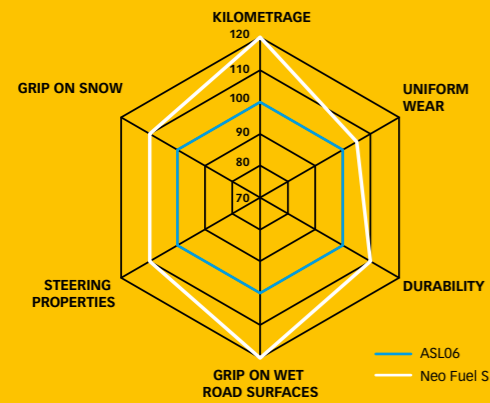

NEO FUEL S+

- This steering axle tyre is specially designed for long distances
- Special rubber compound for low rolling resistance and increased mileage
- Wide casing construction with extra strong shoulders for more stability
- With High-Load specification for Euro 6 trucks
- With 3PMSF label

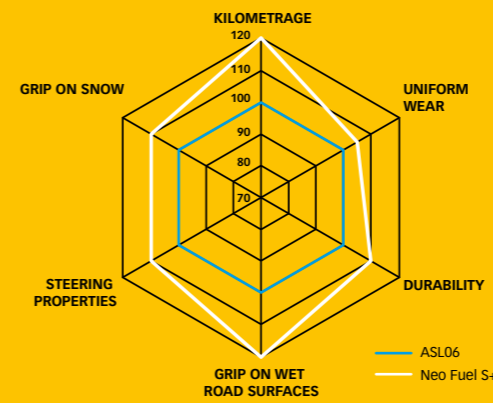

018

019

Size	L/S Index	TL/TT	M+S				DB	Class	Available
295/60R22.5	150/147K (149/146L)	TL	M+S		C	D	72		Immediately
295/80R22.5	154/149M	TL	M+S		B	B	72		Immediately
315/70R22.5	156/150L (154/150M)	TL	M+S		B	B	72		Immediately
315/80R22.5	158/150L (154/150M)	TL	M+S		B	B	72		Immediately

Size	L/S Index	TL/TT	M+S				DB	Class	Available
295/80R22.5	154/149M	TL	M+S		B	B	72		Immediately
315/60R22.5	154/148L	TL	M+S		B	C	73		Immediately

NEO Fuel in the spotlight:

Check out the NEO-series in

www.aeolus-tyres.com

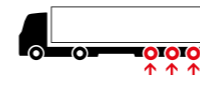
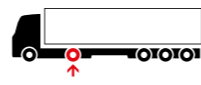

NEO FUEL D

- Drive axle tyre, specially designed for long distances
- Extremely high kilometrages and performance thanks to wide pattern
- High traction on wet and dry roads thanks to pattern with longitudinal grooves and block pattern
- Anti-wear layer in tread compound improves fuel economy, kilometrage and life-span
- Full multi-layer structure makes casing extra strong
- Two tread layers ensure long life-span and low fuel consumption

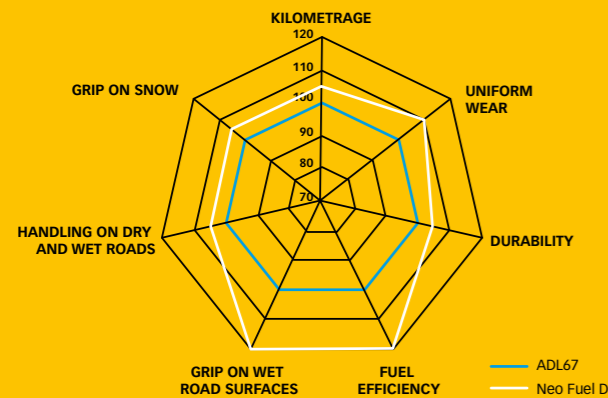

NEO FUEL T+

- Trailer tyres, specially designed for international transport
- Perfect water and heat discharge thanks to pattern with 6 longitudinal grooves
- Uniform wear thanks to special shoulder design (RSR)
- Perfect grip and handling in bends on wet and dry roads thanks to unique pattern design
- Full multi-layer structure makes casing extra strong
- Special tread compound improves fuel economy on long journeys

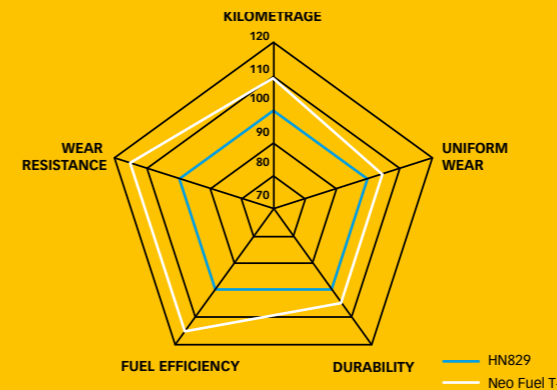

020

021

Size	L/S Index	TL/TT	M+S				DB	Class	Available
295/60R22.5	150/147K (149/146L)	TL	M+S		D	D	74		Immediately
295/80R22.5	152/149M	TL	M+S		D	D	74		Immediately
315/60R22.5	152/148L	TL	M+S		C	C	73		Immediately
315/70R22.5	154/150L (152/148M)	TL	M+S		C	B	74		Immediately
315/80R22.5	156/150L (154/150M)	TL	M+S		C	B	74		Immediately

Size	L/S Index	TL/TT	M+S				DB	Class	Available
385/55R19.5	156J	TL	M+S						2020
385/65R22.5	164K	TL	M+S						2020
435/50R19.5	160J	TL	M+S		C	D	72		Immediately
445/45R19.5	164J	TL	M+S		C	D	72		2020

NEO Fuel in the spotlight: Check out the NEO-series in at www.aeolus-tyres.com

DARE US!



NOTHING CAN STOP US.

No road, no weather, no distance. So captivate and challenge us... because that is what motivates us. Considering this, it's a little weird that it has taken so long to launch our two-year guarantee. But even so, we are still one of the first companies to do so.

No matter what.

Weitere Infos & die Bedingungen finden Sie auf
aeolus-tyres.de/warranty

AEOLUS

NO MATTER WHAT.

NEO Series - The Ultimate Truck Tyre

NEO Construct

NEO CONSTRUCT

THE BEST PERFORMING, THE LONGEST LASTING,
THE STRONGEST



AEOLUS

NO MATTER WHAT

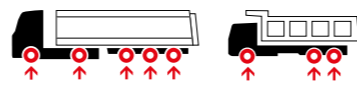

NEO CONSTRUCT G

- Excellent self-cleansing properties thanks to interchanging pattern design
- Minimum wear due to extremely stiff pattern design
- Special transverse grooves improve traction and prevent irregular wear
- Wider and deeper transverse grooves improve kilometrage
- Optimised heel and heel-core design for heavy loads
- Uniform wear thanks to special shoulder design
- Long life-span thanks to extra anti-wear layer

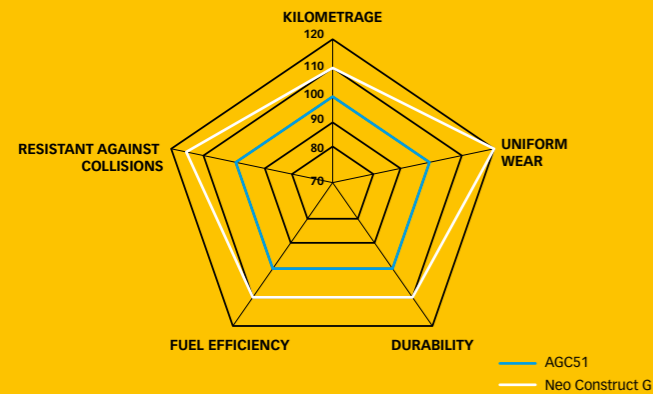

NEO CONSTRUCT D

- Extra wide and deep transversal grooves for perfect driving behaviour
- Extra-stiff tread thanks to block design featuring inter-connected blocks
- Advanced shoulder design offers maximum grip
- Optimised heel and heel-core design for heavy loads
- Excellent resistance against punctures and damage
- Uniform wear thanks to special shoulder design
- Long life-span thanks to extra anti-wear layer

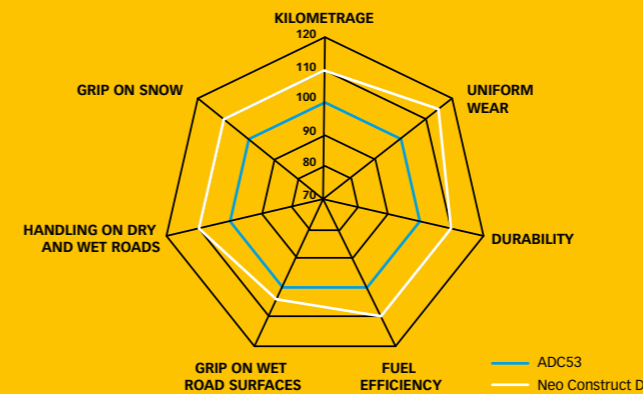

024

025

Size	L/S Index	TL/TT	M+S			DB	Class	Available
13R22.5	156/151K (154/152L)	TL	M+S		C C	73		Immediately
315/80R22.5	158/150K (154/150L)	TL	M+S		C C	73		Immediately
385/65R22.5	164K (158L)	TL	M+S					2020
425/65R22.5	165K	TL	M+S					2020
445/65R22.5	169 K	TL	M+S					2020
325/95R24	162/160K	TL	M+S					2020

Size	L/S Index	TL/TT	M+S			DB	Class	Available
13R22.5	156/150K (154/151L)	TL	M+S		D C	73		Immediately
315/80R22.5	156/150K (154/150M)	TL	M+S		D C	75		Immediately
325/95R24	162/160K	TL	M+S		D C	75		Immediately

NEO Construct in the spotlight: Check out the NEO-series in at www.aeolus-tyres.com

Aeolus AE77

THE ULTIMATE AGRICULTURE TYRE

NO MATTER WHAT.

Robust, durable and reliable? Check. Highly suitable for use on off-road vehicles & crashtenders? Check. Heavy loads and high speeds? No problem.



Size	L/S Index	TRA Code	Rim	Dimensions		Load capacity (kg) 80 km/h	Tyre pressure (kPa) 80 km/h	Pattern depth (mm)	TL/TT
				Width	Diameter				
24R20.5	176F	E-7	18.00	600	1370	7100	590	21	TL
525/65R20.5	173F	E-7	16.00	520	1200	6500	800	21	TL
445/65R22.5	169F	E-7	14.00	443	1149	5800	800	21	TL

AEOLUS-TYRES.COM

Neo Serie - The Ultimate Truck Tyre

NEO Winter

NEO WINTER

NOT MEANT FOR THE FAINT HEARTED



The NEO series are manufactured under a patent and know how license from **Pirelli Tyre**

AEOLUS
NO MATTER WHAT

027

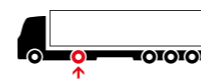
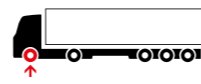

NEO WINTER S

- Suitable for Euro 6 legislation (High Load)
- Extreme traction due to innovative pattern design
- Special shoulder design ensures comfort and grip when steering
- Special winter-oriented rubber compound for grip in all circumstances

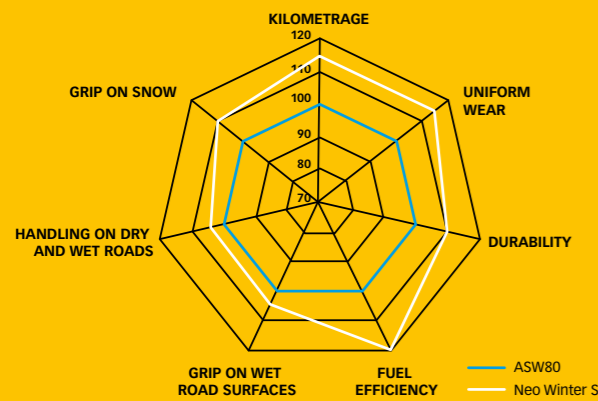

NEO WINTER D

- Drive axle tyre for winter conditions
- Perfect grip in snow, ice and wet conditions thanks to high-tech strip pattern (3D sipes)
- Extra belt layer (FRC) reinforces casing, improves re-profiling and enables re-profiling
- Lasting high traction thanks to special 3D pattern design
- Uniform wear thanks to reinforced shoulder design (RSR)
- Excellent life-span thanks to extra anti-wear layer in tread compound

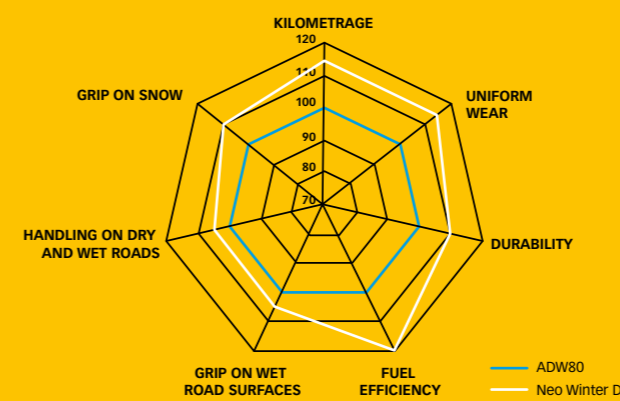

028

029

Size	L/S Index	TL/TT	M+S				DB	Class	Available
275/70R22.5	150/148J (152/148E)	TL	M+S		D	C	73		Immediately
295/60R22.5	149/146L (150/147K)	TL	M+S						2020
295/80R22.5	154/149M	TL	M+S		D	C	74		Immediately
315/60R22.5	154/148L	TL	M+S						2020
315/70R22.5	156/150L (154/150M)	TL	M+S		D	C	74		Immediately
315/80R22.5	158/150L (154/150M)	TL	M+S		D	C	74		Immediately
385/55R22.5	160K (158L)	TL	M+S		D	C	73		Immediately
385/65R22.5	164K (158L)	TL	M+S		D	C	73		Immediately

Size	L/S Index	TL/TT	M+S				DB	Class	Available
295/60R22.5	149/146L (150/147K)	TL	M+S						2020
295/80R22.5	152/148M	TL	M+S						2020
315/60R22.5	152/148L	TL	M+S						2020
315/70R22.5	154/150L (152/148M)	TL	M+S		D	B	75		Immediately
315/80R22.5	154/150M (156/150L)	TL	M+S						2020

NEO Winter in the spotlight:

Check out the NEO-series in at www.aeolus-tyres.com

**THE HARDER YOU PUNISH ME
THE MORE YOU CONTROL ME
THE EASIER YOU LET ULTIMATE
DRIVING LOOK**

NO MATTER WHAT.



AL59
AVAILABLE UP TO 33 INCH

AGC28
M+S

AEX1
MOBILE EXCAVATOR 10.00-20
DOUBLE ASSEMBLY

AEOLUS-TYRES.COM

Neo Serie - The Ultimate Truck Tyre

NEO Urban

NEO URBAN

BRAKE. PULL. GO. THE CITY IS YOURS.



The NEO series
are manufactured
under a patent and
know how license from
Pirelli Tyre

AEOLUS
NO MATTER WHAT

031



NEO URBAN G

- Tyre specifically for city buses and urban transport
- Deeper pattern for extra high kilometrage
- Better driving behaviour due to pattern with 4 longitudinal grooves
- Excellent heat discharge thanks to S-shaped design and special deep sipe design
- Extra-strong side wall protection minimises damage caused by pavements
- Low rolling resistance offers high kilometrages due to special silicone additive in compound
- Full multi-layer structure makes casing extra strong

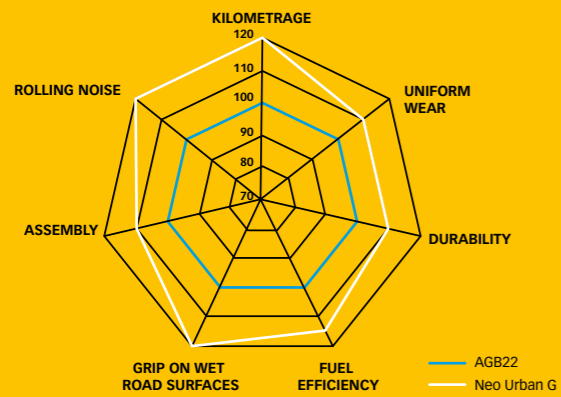

**THE ONES
THAT
STRIKE YOU.
A RANGE TO
IMPRESS.**

Size	L/S Index	TL/TT	M+S				DB	Class	Available
11R22.5	148/145J (151/148E)	TL	M+S						2020
275/70R22.5	150/148J (152/148E)	TL	M+S		C	C	72		Immediately
295/80R22.5	152/149J (154/150E)	TL	M+S		C	C	73		Immediately
305/70R22.5	152/150L	TL	M+S		D	C	73		Immediately



SIZE AND PATTERN OVERVIEW

STEERING AXLE

Size	Pattern	M+S		TL/TT	L/S Index				
								DB	Class
9.5R17.5	ASR24	M+S		TL	136/134M	D	C	73	
205/75R17.5	ASR35	M+S		TL	124/122M	D	C	71	
215/75R17.5	NEO Allroads S	M+S		TL	126/124M	D	C	73	
225/75R17.5	ASR35	M+S		TL	129/127M	D	C	71	
235/75R17.5	NEO Allroads S	M+S		TL	132/130M	C	C	71	
245/70R17.5	ASR35	M+S		TL	136/134M	D	C	71	
265/70R19.5	HN257	M+S		TL	140/138M	D	C	73	
285/70R19.5	NEO Allroads S	M+S		TL	145/143M (146/144L)	C	C	73	
9R22.5	ASL06	M+S		TL	136/134M	E	B	73	
11R22.5	HN257	M+S		TL	146/143M (148/145L)	D	C	73	
12R22.5	HN257	M+S		TL	152/149M	D	C	73	
255/70R22.5	HN257	M+S		TL	140/137M (140/140L)	D	C	73	
275/70R22.5	HN257	M+S		TL	148/145M	C	C	73	
275/70R22.5	NEO Winter S	M+S		TL	150/148J (152/148E)	D	C	73	
275/80R22.5	HN267	M+S		TL	149/146L (148/145M)	D	C	76	
295/60R22.5	NEO Fuel S	M+S		TL	150/147K (149/146L)	C	D	72	
295/80R22.5	NEO Fuel S HL	M+S		TL	154/149M	B	B	72	
295/80R22.5	NEO Allroads S HL	M+S		TL	154/149M	C	C	73	
295/80R22.5	NEO Winter S HL	M+S		TL	154/149M	D	C	74	
315/60R22.5	NEO Fuel S+	M+S		TL	154/148L	B	C	73	
315/70R22.5	NEO Allroads S HL	M+S		TL	154/150L (152/148M)	B	B	73	
315/70R22.5	NEO Fuel S HL	M+S		TL	156/150L (154/150M)	B	B	72	
315/70R22.5	NEO Winter S	M+S		TL	154/150L (152/148M)	D	C	73	
315/80R22.5	NEO Fuel S HL	M+S		TL	158/150L (154/150M)	B	B	72	
315/80R22.5	NEO Allroads S	M+S		TL	158/150L (154/150M)	C	C	73	
315/80R22.5	NEO Winter S	M+S		TL	158/150L (154/150M)	D	C	73	
385/55R22.5	NEO Allroads S+	M+S		TL	160K (158L)	B	B	72	
385/55R22.5	NEO Winter S	M+S		TL	160K (158L)	D	C	73	
385/65R22.5	NEO Allroads S+ HL	M+S		TL	164K (158L)	B	A	73	
385/65R22.5	NEO Winter S HL	M+S		TL	164K (158L)	D	C	73	

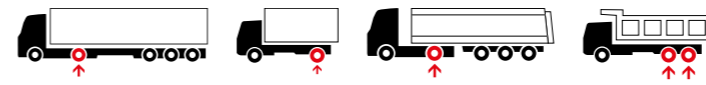

SIZE AND PATTERN OVERVIEW

DRIVE AXLE

Size	Pattern	M+S		TL/TT	L/S Index				
								DB	Class
9.5R17.5	ADR35	M+S		TL	136/134M	E	C	73	
205/75R17.5	ADR35	M+S		TL	124/122M	E	C	73	
215/75R17.5	NEO Allroads D	M+S		TL	126/124M	E	D	73	
225/75R17.5	ADR35	M+S		TL	129/127M	E	C	73	
235/75R17.5	NEO Allroads D	M+S		TL	132/130M	C	D	73	
245/70R17.5	ADR35	M+S		TL	136/134M	E	C	73	
245/70R19.5	HN366+	M+S		TL	136/134M (136/135J)	E	C	76	
265/70R19.5	NEO Allroads D	M+S		TL	140/138M	C	D	73	
285/70R19.5	NEO Allroads D	M+S		TL	145/143M (146/144L)	C	C	73	
12.00R20	ADC53	M+S		TT Set	154/151K	E	C	73	
10R22.5	HN355	M+S		TL	144/142M	D	C	73	
11R22.5	ADC53	M+S		TL	146/143L (148/145K)	E	B	73	
12R22.5	HN355	M+S		TL	152/149M	D	C	73	
12R22.5	ADC53	M+S		TL	152/149L	D	C	71	
13R22.5	NEO Construct D	M+S		TL	156/150K	D	C	73	
13R22.5	HN352	M+S		TL	154/151K (156/150G)	D	B	73	
13R22.5	ADC53	M+S		TL	154/151K (156/150G)	D	C	73	
255/70R22.5	HN355	M+S		TL	140/137M (140/140L)	D	C	73	
275/70R22.5	HN355	M+S		TL	148/145M	D	C	73	
275/80R22.5	HN306	M+S		TL	149/146L (150/147K)	D	C	76	
295/60R22.5	NEO Fuel D	M+S		TL	150/147K (149/146L)	D	D	74	
295/60R22.5	NEO Allroads D+	M+S		TL	149/146L (150/147K)	D	B	73	
295/80R22.5	NEO Fuel D	M+S		TL	154/149M	D	B	74	
295/80R22.5	NEO Allroads D+	M+S		TL	152/148M	D	B	73	
295/80R22.5	ADC53	M+S		TL	152/149M	D	C	76	
295/80R22.5	ADW80	M+S		TL	152/148M	F	C	73	
315/60R22.5	NEO Allroads D+	M+S		TL	152/148L	D	B	73	
315/60R22.5	NEO Fuel D	M+S		TL	152/148L	C	C	73	
315/70R22.5	NEO Allroads D+	M+S		TL	152/148M (154/150L)	D	B	73	
315/70R22.5	NEO Fuel D	M+S		TL	152/148M (154/150L)	C	B	74	
315/70R22.5	NEO Winter D	M+S		TL	154/150L (152/148M)	E	C	74	
315/80R22.5	NEO Fuel D	M+S		TL	156/150L (154/150M)	C	B	74	
315/80R22.5	NEO Allroads D+	M+S		TL	156/150L (154/150M)	D	B	73	
315/80R22.5	NEO Construct D	M+S		TL	156/150K (154/150M)	D	C	75	
315/80R22.5	ADC53	M+S		TL	154/151M (156/150L)	C	C	73	
315/80R22.5	HN352	M+S		TL	156/150K	D	B	72	
315/80R22.5	ADW80	M+S		TL	154/151M (156/150L)	F	C	73	
325/95R24	NEO Construct D	M+S		TL	162/160K	D	C	75	



**NEO
ALLROADS T2**



**NEO
FUEL T+**



HN230+



ATR65



HN828+



SIZE AND PATTERN OVERVIEW TRAILER

Size	Pattern	M+S		TL/TT	L/S Index			DB	Class
8.25R15	HN230+	M+S		TT Set	143/141G (141/140J)	C	C	73	
10.00R15	HN230+	M+S		TT Set	148/145G (146/144J)	C	C	73	
205/65R17.5	NEO Allroads T2	M+S		TL	129/127J (132/132F)	C	C	73	
215/75R17.5	NEO Allroads T2	M+S		TL	135/133J	C	C	73	
235/75R17.5	NEO Allroads T2	M+S		TL	143/141J (144/144F)	C	C	73	
245/70R17.5	NEO Allroads T2	M+S		TL	143/141J (146/146F)	C	C	73	
245/70R19.5	HN828+	M+S		TL	141/140J	D	C	76	
265/70R19.5	NEO Allroads T2	M+S		TL	143/141J (146F)	C	C	73	
285/70R19.5	NEO Allroads T2	M+S		TL	150/148J	C	C	71	
385/55R19.5	ATR65	M+S		TL	156J	C	C	73	
435/50R19.5	NEO Fuel T+	M+S		TL	160J	C	D	72	
445/45R19.5	NEO Fuel T+	M+S		TL	164J	C	D	72	
385/55R22.5	NEO Allroads T2	M+S		TL	160K	B	C	73	
385/65R22.5	NEO Allroads T2 HL	M+S		TL	164K (158L)	B	C	73	
385/65R22.5	ATR65	M+S		TL	160K (158L)	B	C	73	
425/65R22.5	NEO Allroads T2	M+S		TL	165K	C	C	71	
445/65R22.5	NEO Allroads T2	M+S		TL	169 K	C	C	71	

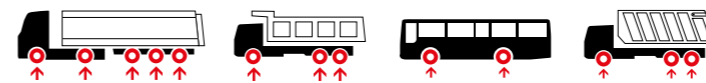

SIZE AND PATTERN OVERVIEW ALL POSITIONS

Size	Pattern	M+S		TL/TT	L/S Index			DB	Class
7.50R16	HN08	M+S		TT Set	122/118L	E	C	71	
8.25R16	HN08	M+S		TT Set	126/122L	E	C	71	
215/75R17.5	AGC28	M+S		TL	135/133J	E	C	73	
235/75R17.5	AGC28	M+S		TL	143/141J (144/144F)	E	C	73	
245/70R17.5	AGC28	M+S		TL	143/141J (144/144F)	E	C	73	
265/70R19.5	AGC28	M+S		TL	143/141J	E	C	73	
7.50R20	HN08	M+S		TL	130/128K	E	C	76	
8.25R20	HN08	M+S		TT Set	136/134K	E	C	71	
9.00R20	HN08	M+S		TT Set	144/142K	D	C	71	
10.00R20	HN08	M+S		TT Set	146/143K	D	C	71	
11.00R20	HN08	M+S		TT Set	149/145K	D	C	71	
12.00R20	HN08	M+S		TT Set	154/149K	D	C	71	
10R22.5	HN08	M+S		TL	144/142L	D	C	71	
11R22.5	HN08	M+S		TL	146/143L (148/145K)	D	C	71	
11R22.5	AGB20+	M+S		TL	148/145J (151/148E)	D	C	73	
12R22.5	HN08	M+S		TL	152/149L	C	C	71	
13R22.5	NEO Construct G	M+S		TL	156/150K (154/150M)	C	C	73	
13R22.5	HN253	M+S		TL	156/150K (154/151L)	D	C	71	
13R22.5	HN10	M+S		TL	154/151G (156/150F)	E	C	76	
265/70R19.5	AGB23	M+S		TL	143/141J	D	C	73	
275/70R22.5	AGC28	M+S		TL	148/145L	E	C	73	
275/70R22.5	NEO Urban G	M+S		TL	148/145J (152/148E)	D	C	73	
295/80R22.5	NEO Urban G	M+S		TL	152/148J (154/150E)	C	C	73	
305/70R22.5	NEO Urban G	M+S		TL	152/150L	D	C	73	
315/80R22.5	NEO Construct G	M+S		TL	158/150K	C	C	73	
315/80R22.5	HN08	M+S		TL	154/151L (156/150K)	C	C	71	
385/55R22.5	AGC28	M+S		TL	160K (158L)	C	C	73	
385/65R22.5	AGC28	M+S		TL	160K (158L)	C	C	73	
425/65R22.5	AGC28	M+S		TL	165K	C	C	73	
445/65R22.5	AGC28	M+S		TL	169 K	C	C	73	
12.00R24	HN08	M+S		TT Set	160/157K	C	C	71	

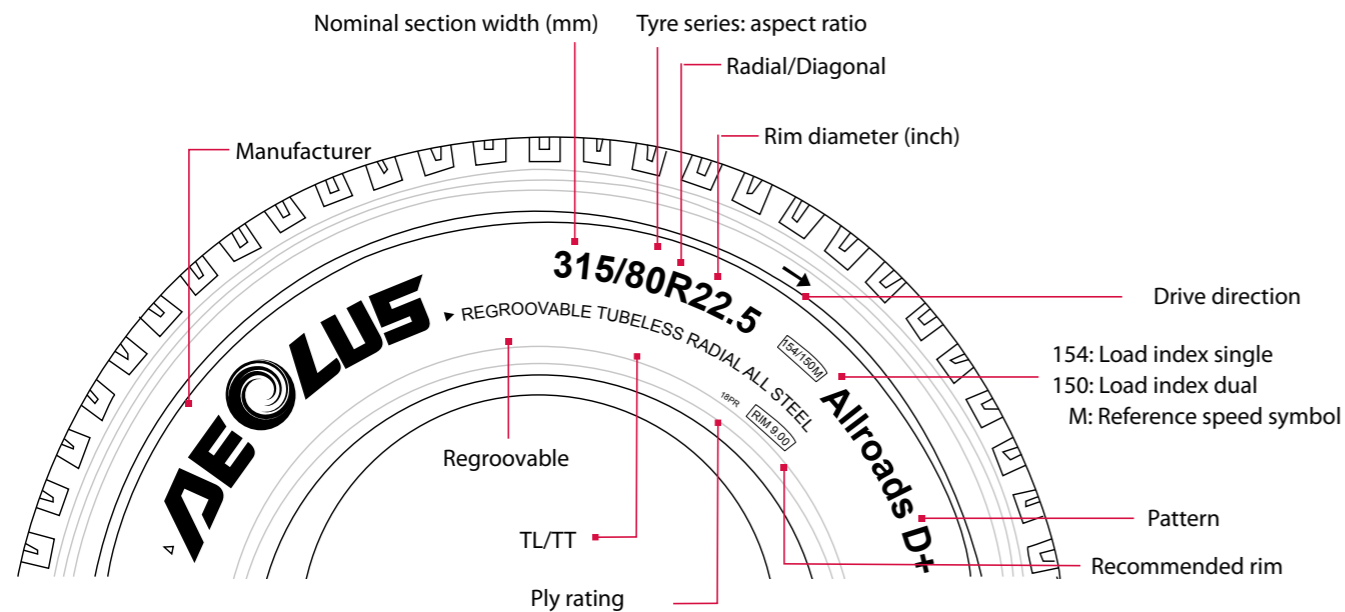

TECHNICAL SPECIFICATIONS

- A** External diameter
- B** Width
- H** Loaded radius
- F** Rim diameter
- Q** Cross section
- Z** Minimum distance, twin tyres

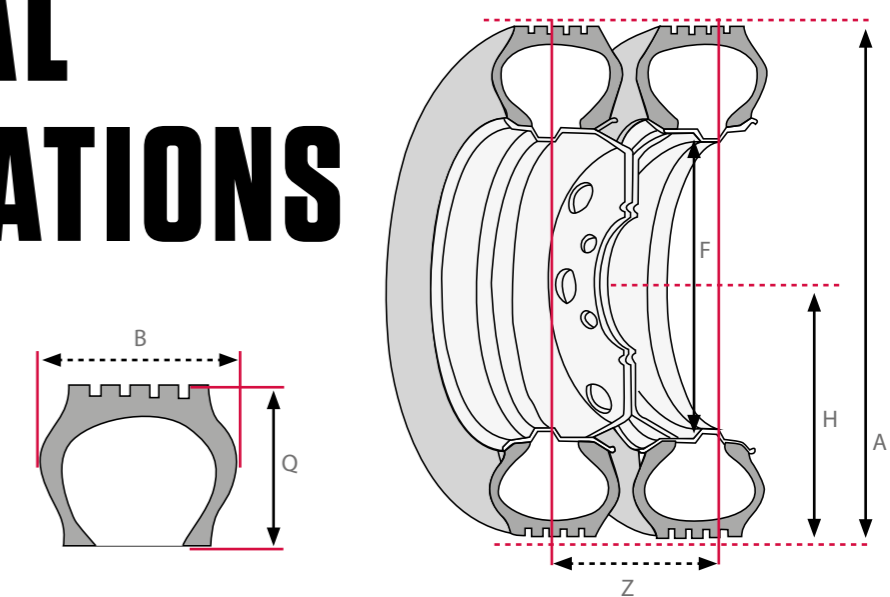

LOAD INDEX

Loadindex	Loading capacity in kg
120	1400
121	1450
122	1500
123	1550
124	1600
125	1650
126	1700
127	1750
128	1800
129	1850
130	1900
131	1950
132	2000
133	2060
134	2120
135	2180
136	2240
137	2300
138	2360
139	2430
140	2500
141	2575
142	2650
143	2725
144	2800
145	2900
146	3000
147	3075
148	3150
149	3250
150	3350
151	3450
152	3550
153	3650
154	3750

SPEED INDEX

Speed symbol	Speed in km
F	80
G	90
J	100
K	110
L	120
M	130
N	140

DEVIATIONS IN LOAD CAPACITY DEPENDING ON SPEED



















The data shown directly below in the table on this page correspond to the international ETRTO standard and are intended only to provide information for the reader.

Always contact us by telephone or e-mail in special cases – in the case of cargoes which exceed explicit load limits as indicated on the side wall of the tyre in question or as specified in the instructions in this catalogue. In all cases in which the necessary air pressure in the tyres has to be increased to more than 10 bar on the basis of the data supplied here: Reduce the weight of your intended cargo until you are able to drive with a maximum pressure of 10 bar. If despite

this there is still a need to drive with a pressure in excess of 10 bar, as well as carrying out the basically essential check with us, you will also need to check the specified limits of the applicable rim manufacturer, as well as expressly following the regulations for fitment and use of both the components in question (tyres and wheels).

In addition, the following tyre loading capacities are applicable in special cases: Buses and coaches (M3 class 1): + 15% loading capacity if the average speed is below 40 km/h. Buses and coaches (M3 class 2): + 10% loading capacity if the average speed remains below 60 km/h.

Speed (km/h) Speed Symbol	Speed in km						Pressure compensation (%)
	F	G	J	K	L	M	
0	+150	+150	+150	+150	+150	+150	40
5	+110	+110	+110	+110	+110	+110	40
10	+80	+80	+80	+80	+80	+80	30
15	+65	+65	+65	+65	+65	+65	25
20	+50	+50	+50	+50	+50	+50	21
25	+35	+35	+35	+35	+35	+35	17
30	+25	+25	+25	+25	+25	+25	13
35	+19	+19	+19	+19	+19	+19	11
40	+15	+15	+15	+15	+15	+15	10
45	+13	+13	+13	+13	+13	+13	9
50	+12	+12	+12	+12	+12	+12	8
55	+11	+11	+11	+11	+11	+11	7
60	+10	+10	+10	+10	+10	+10	6
65	+7.5	+8.5	+8.5	+8.5	+8.5	+8.5	4
70	+5.0	+7.0	+7.0	+7.0	+7.0	+7.0	2
75	+2.5	+5.5	+5.5	+5.5	+5.5	+5.5	1
80	(0)	4.0	+4.0	+4.0	+4.0	+4.0	0
85		2.0	+3.0	+3.0	+3.0	+3.0	0
90		(0)	+2.0	+2.0	+2.0	+2.0	0
95			+1.0	+1.0	+1.0	+1.0	0
100			(0)	0	0	0	0
110				(0)	0	0	0
120					(0)	0	0
130						(0)	0

Size	Pattern	L/S-index	L/S-index 2	PR	TL/TT	M+S		Width (mm)	Overall diameter (mm)	Loaded radius (mm)	Rolling circ. (mm)	Tread depth (mm)	Recommended wheel	Permitted wheel	Bearing capacity per tyre 1		Bearing capacity per tyre 2		Tyre pressure (bar)	Weight (kg)	Rolling resistance	Grip on wet surface	Noise Emission (dB)	Noise Emission (Class)	Vehicle class
															Single	Dual	Single	Dual							
385/55R22.5	ATR65	160J	(158L)	18	TL	M+S		386	1004	461	3151	16.5	11.75 - 22.5	12.25 - 22.5	4500 - 100		4250 - 120		9.0	71.3	C	C	73	CAT-2	C3
385/55R22.5	NEO ALLROADS S+	160K	(158L)	20	TL	M+S		384	1003	460	3059	15	11.75 - 22.5		4500 - 110		4250 - 110		9.0	71.3	B	B	72	CAT-2	C3
385/55R22.5	NEO ALLROADS T2	160K	(158L)	18	TL	M+S		385	1069		3260	15.5	11.75 - 22.5		4500 - 110				9.0	73.3	B	C	73	CAT-2	C3
385/55R22.5	NEO WINTER S	160K	(158L)	20	TL	M+S		386	1004	461	3151	16.5	11.75 - 22.5		4500 - 110		4250 - 120		9.0	73.3	D	C	73	CAT-2	C3
385/65R22.5	ATR65	160K	(158L)	20	TL	M+S		384	1069		3260	16.8	11.75 - 22.5		4500 - 110		4250 - 120		9.0	77.75	B	C	73	CAT-2	C3
385/65R22.5	AGC28	160K	(158L)	20	TL	M+S		385	1070	491	3242	16.8	11.75 - 22.5	12.25 - 22.5	4500 - 110		4250 - 120		9.0	75.91	C	C	73	CAT-1	C3
385/65R22.5	NEO ALLROADS S+	164K	(158L)	20	TL	M+S		382	1069		3260	15	11.75 - 22.5		5000 - 110		4250 - 120		9.0	74.49	B	A	73	CAT-2	C3
385/65R22.5	NEO ALLROADS T2	164K	(158L)	20	TL	M+S		380	1077	498	3285	17.0	11.75 - 22.5	12.25 - 22.5	4500 - 110		4250 - 120		9.3	76.75	B	C	73	CAT-2	C3
385/65R22.5	NEO WINTER S	164K	(158L)	18	TL	M+S		385	1064		3245	13.5	11.75 - 22.5		5000 - 110		4250 - 120		9.0	73.19	D	C	73	CAT-2	C3
425/65R22.5	AGC28	165K		20	TL	M+S		422	1118	515	3387	16.5	13.00 - 22.5	12.25 - 22.5	5150 - 110				8.3	87.91	C	C	73	CAT-1	C3
425/65R22.5	NEO ALLROADS T2	165K		20	TL	M+S		414	1119		3413	16.5	12.25 - 22.5		5150 - 110				8.25	85.96	C	C	71	CAT-2	C3
445/65R22.5	AGC28	169K		20	TL	M+S		453	1147	526	3602	16.5	14.00 - 22.5	13.00 - 22.5	5800 - 110				8.3	94.45	C	C	73	CAT-1	C3
445/65R22.5	NEO ALLROADS T2	169K		20	TL	M+S		440	1146		3495	16.5	13.00 - 22.5		5800 - 110				9.0	94.1	C	C	71	CAT-2	C3
12.00R24	AGC51	160/157K		20	TT SET	M+S		314	1222	572	3727	17.5	8.5 - 24	8.50V 9.0 - 24	4500 - 110	4125 - 110			9.0	90.73	D	C	73	CAT-2	C3
12.00R24	HN08	160/157K		20	TT SET	M+S		315	1223		3730	17.5	8.50 - 24	8.50V 9.0 - 20	4500 - 110	4125 - 110			9.0	88.11	C	C	71	CAT-2	C3
325/95R24	NEO CONSTRUCT G	162/160K		22	TL	M+S		322	1231		3755	19.0	8.50 - 24						8.5	80.58	C	C	73	CAT-1	C3
325/95R24	NEO CONSTRUCT D	162/160K		22	TL	M+S		314	1230		3725	20.6	8.5 - 24		4750	4500			8.5	82.55	D	C	75	CAT-2	C3
11R24.5	ADW81	149/146L		16	TL	M+S		282	1105		3370	20.6	8.25 - 24.5	7.50 - 24.5	3250 - 120	3000 - 120			8.3	62.0					C3
11R24.5	HN257	148/144M		16	TL			290	1096	506	3342	15.0	8.25 - 24.5					8.3	58	D	C	73	CAT-2	C3	
11R24.5	HN306	149/146L		16	TL	M+S		282	1104		3367	20.6	8.25 - 24.5	7.50 - 24.5	3250 - 120	3000 - 120			8.3	60.11					C3
12R24.5	HN08	154/151L		18	TL							17.0	9.00 - 22.5	8.25 - 22.5				8.3	64.12	D	C	71	CAT-2	C3	
305/75R24.5	ASL38	152/148M		16	TL			305	1077		3285	14.0	8.50 - 24.5		3550 - 130	3150 - 130			9.0	64.12	D	C	73	CAT-2	C3

OUR TOTAL CONCEPT AT THE LOWEST TOTAL COST

Real costs are important to transport companies. This is something we fully realise. We thus try to minimise costs by developing top quality tyres that offer a long life-span, such as the Aeolus Life Cycle. Let's take our new Aeolus truck tyre as an example. When these tyres reach the end of their service life (in good condition), regrooving can be used to extend their life-span. Thanks to a high rubber percentage, tyre specialists can easily prolong use by cutting 3 mm deeper into the tyre. After regrooving, Aeolus Casing Management & high quality tread renewal are other important tools for extending life-span and reducing costs.

Regrooving

Regrooving is possible on Aeolus tyres which, in accordance with ECE regulation 54, feature the word 'REGROOVABLE' on both side walls. In addition, they must, in accordance with §36 Erläuterung 6 StVZO 4.2 (German road authorisation), have a remaining pattern depth of at least 2 mm. We recommend regrooving when the remaining pattern depth is 3 mm. Irregular wear and blocking points must also be taken into account when doing so. The tyres can only be regrooved by a qualified specialist, so the option of tread renewal is not put at risk.

NEO ALLROADS S

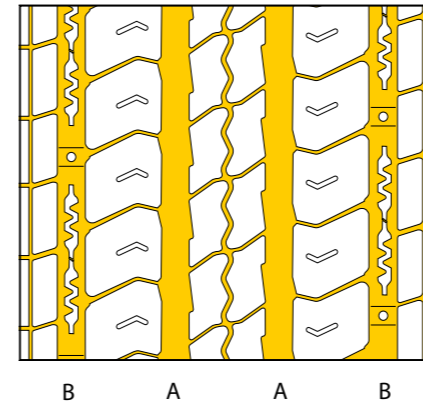

Size	Depth (mm)	Width (mm)
205/75R17.5	A:3;B:2	7-8
215/75R17.5	A:2.5;B:2	7-8
225/75R17.5	A:3;B:2	7-8
235/75R17.5	A:3;B:2	7-8
245/70R17.5	A:3;B:2	7-8
265/70R19.5	A:3;B:2	7-8
295/60R22.5	A:3-3.5;B:2-2.5	10-12
295/80R22.5	A:3-3.5;B:2-2.5	10-12
315/70R22.5	A:3-3.5;B:2-2.5	10-12
315/80R22.5	A:3-3.5;B:2-2.5	10-12

NEO ALLROADS S+

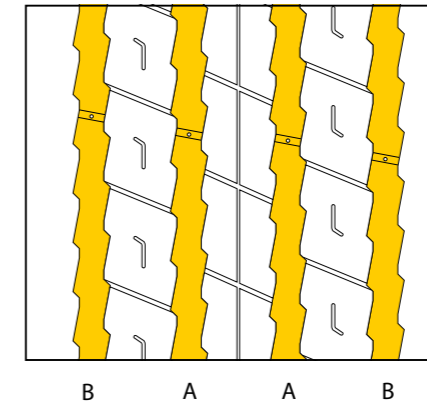

Size	Depth (mm)	Width (mm)
385/55R22.5	A:3-3.5;B:2-2.5	A:10-12;B:5-7
385/65R22.5	A:3-3.5;B:2-2.5	A:10-12;B:5-7

NEO ALLROADS D

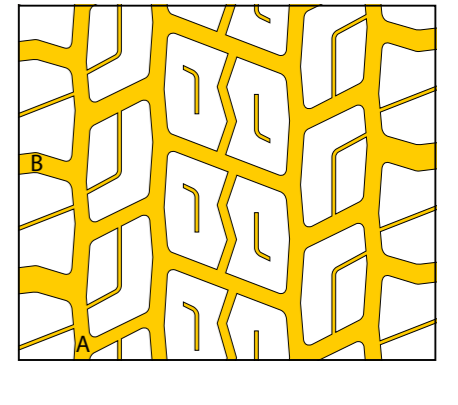

Size	Depth (mm)	Width (mm)
205/75R17.5	2-2.5	A:7-8;B:5-8
215/75R17.5	2	A:7-8;B:5-7
225/75R17.5	2-2.5	A:7-8;B:5-7
235/75R17.5	2-2.5	A:7-8;B:5-7
245/70R17.5	2-2.5	A:9-11;B:5-7
265/70R19.5	2-2.5	A:7-9;B:3-5
285/70R19.5	2-2.5	A:7-9;B:3-5

NEO CONSTRUCT G

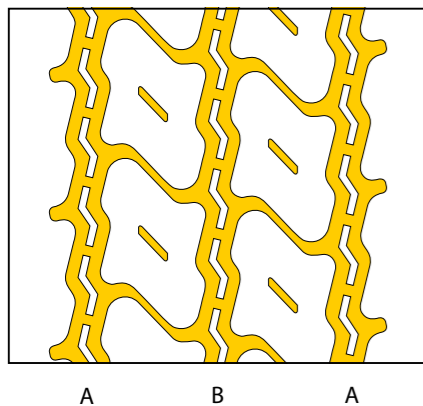

Size	Depth (mm)	Width (mm)
13R22.5	A:3-3.5;B:2-2.5	10-12
315/80R22.5	A:3-3.5;B:2-2.5	10-12
385/65R22.5	A:3-3.5;B:2-2.5	10-12
425/65R22.5	A:3-3.5;B:2-2.5	10-12
445/65R22.5	A:3-3.5;B:2-2.5	10-12
325/95R24	A:3-3.5;B:2-2.5	10-12

NEO CONSTRUCT D

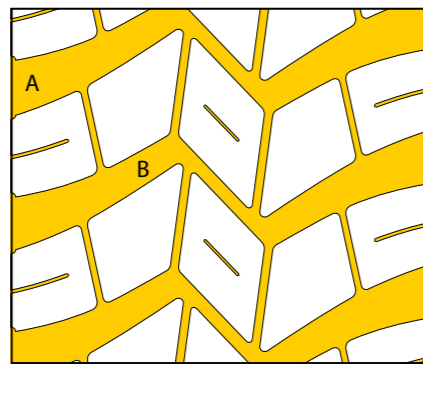

Size	Depth (mm)	Width (mm)
13R22.5	2.5	A:10-12;B:5-7
315/80R22.5	2-2.5	A:10-12;B:5-7
325/95R24	2-2.5	A:10-12;B:5-7

NEO URBAN G

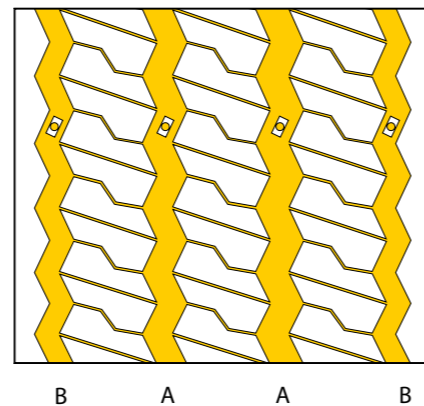

Size	Depth (mm)	Width (mm)
11R22.5	A;4 B;3	7-8
275/70R22.5	A;4 B;3	7-8
295/80R22.5	A;4 B;3	7-8

NEO ALLROADS D+

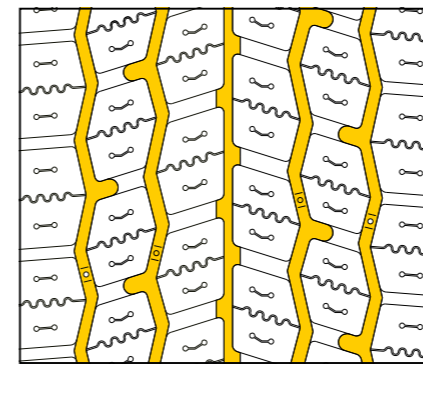

Size	Depth (mm)	Width (mm)
295/60R22.5	2-2.5	5-7
295/80R22.5	2-2.5	5-7
315/60R22.5	2-2.5	5-7
315/70R22.5	2-2.5	5-7
315/80R22.5	2-2.5	5-7

NEO ALLROADS T2

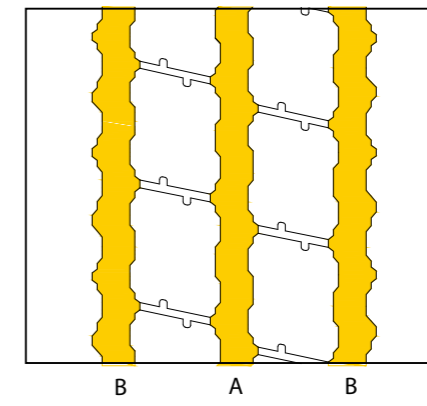

Size	Depth (mm)	Width (mm)
205/65R17.5	A:2.5;B:2	7-8
215/75R17.5	A:2.5;B:2	7-8
235/75R17.5	A:3;B:2	7-8
245/70R17.5	A:3;B:2	7-8
265/70R17.5	A:3;B:2	7-8

NEO ALLROADS T2

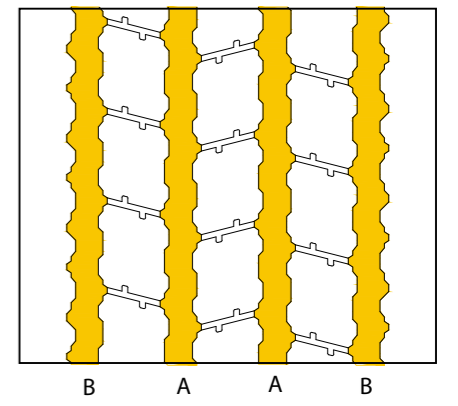

Size	Depth (mm)	Width (mm)
285/70R19.5	A:3;B:2	7-9
385/55R19.5	A:3-3.5;B:2-2.6	7-8
385/65R22.5	A:3-3.5;B:2-2.5	7-8
425/65R22.5	A:3-3.5;B:2-2.6	7-8
445/65R22.5	A:3-3.5;B:2-2.5	7-8

NEO FUEL S

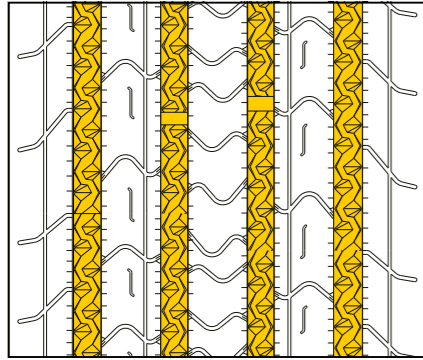

B A A B

Size	Depth (mm)	Width (mm)
295/60R22.5	A:2.5;B:2	5-6
295/80R22.5	A:3-3.5;B:2-2.5	5-6
315/60R22.5	A:3-3.5;B:2-2.5	5-6
315/70R22.5	A:3-3.5;B:2-2.5	5-6
315/80R22.5	A:3-3.5;B:2-2.5	5-6

NEO FUEL D

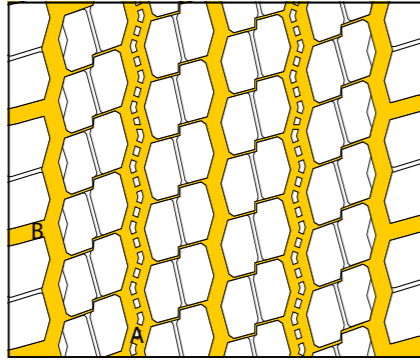

B A A A A B

Size	Depth (mm)	Width (mm)
295/60R22.5	A:2.5-3;B:2-2.5	A:10-12;B:5-7
295/80R22.5	A:3-3.5;B:2-2.5	A:10-12;B:5-7
315/60R22.5	A:3-3.5;B:2-2.5	A:10-12;B:5-7
315/70R22.5	A:3-3.5;B:2-2.5	A:10-12;B:5-7
315/80R22.5	A:3-3.5;B:2-2.5	A:10-12;B:5-7

NEO FUEL T+

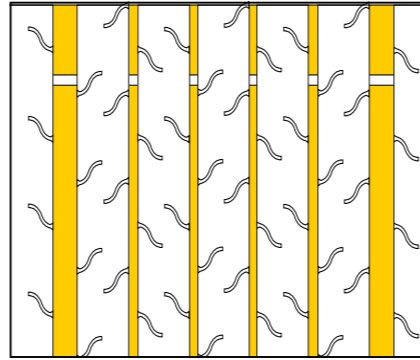

B A A A A B

Size	Depth (mm)	Width (mm)
385/55R19.5	A:3, B:3	A: 3, B:7-8
435/50R19.5	A:3, B:3	A: 3, B:7-8
445/45R19.5	A:3, B:3	A: 3, B:7-8
385/65R22.5	A:3, B:3	A: 3, B:7-8

ASR69

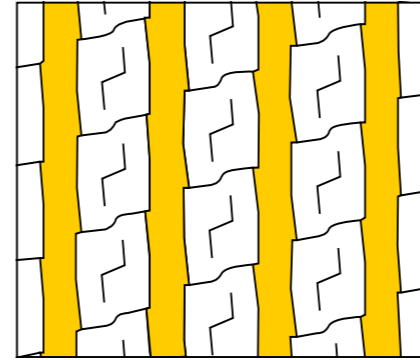

B A A B

Size	Depth (mm)	Width (mm)
295/80R22.5	A:3-3.5;B:2-2.5	10-12
315/70R22.5	A:3-3.5;B:2-2.5	10-12
315/80R22.5	A:3-3.5;B:2-2.5	10-12

ADR69

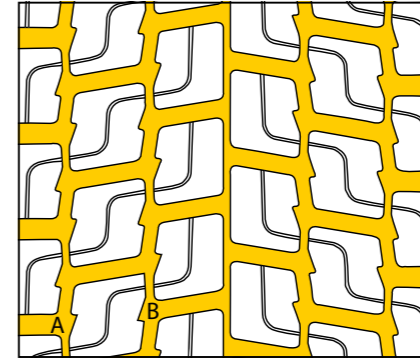

B A A B

Size	Depth (mm)	Width (mm)
295/80R22.5	2-2.5	A:10-12;B:5-7
315/70R22.5	2-2.5	A:10-12;B:5-7
315/80R22.5	2-2.5	A:10-12;B:5-7

ATR65

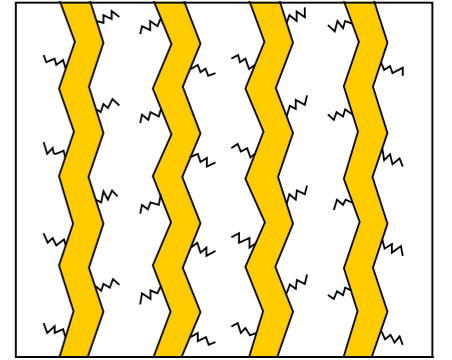

B A A B

Size	Depth (mm)	Width (mm)
245/70R17.5	A:2.5;B:2	7-9
285/70R19.5	A:3;B:2	7-9
265/70R19.5	A:3;B:2	7-9
385/55R22.5	A:3-3.5;B:2-2.6	7-9
385/65R22.5	A:3-3.5;B:2-2.5	7-9
425/65R22.5	A:3-3.5;B:2-2.6	7-9
445/65R22.5	A:3-3.5;B:2-2.5	7-9

NEO WINTER S

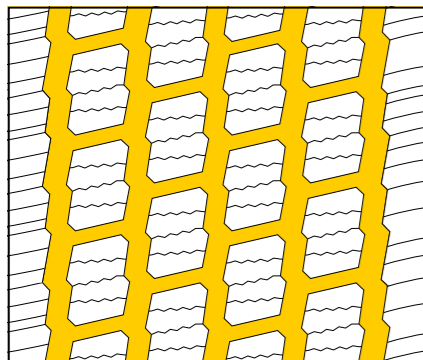

B A A A B

Size	Depth (mm)	Width (mm)
295/60R22.5	A:3-3.5;B:2-2.5	10-12
295/80R22.5	A:3-3.5;B:2-2.5	10-12
315/60R22.5	A:3-3.5;B:2-2.5	10-12
315/70R22.5	A:3-3.5;B:2-2.5	10-12
315/80R22.5	A:3-3.5;B:2-2.5	10-12
385/55R22.5	A:3-3.5;B:2-2.5	10-12
385/65R22.5	A:3-3.5;B:2-2.5	10-12

NEO WINTER D

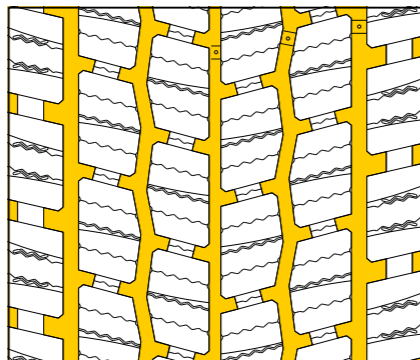

B A A A B

Size	Depth (mm)	Width (mm)
295/60R22.5	2-2.5	5-7
295/80R22.5	2-2.5	5-7
315/60R22.5	2-2.5	5-7
315/70R22.5	2-2.5	5-7
315/80R22.5	2-2.5	5-7

AGC28

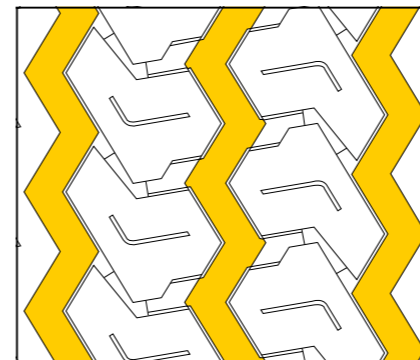

B A B

Size	Depth (mm)	Width (mm)
215/75R17.5	A:2.5;B:2	7-8
235/75R17.5	A:3;B:2	7-8
245/70R17.5	A:3;B:2	7-8
265/70R19.5	A:3;B:2	10-11
275/70R22.5	A:3-3.5;B:2-2.5	10-12
385/55R22.5	A:3-3.5;B:2-2.5	10-12
385/65R22.5	A:3-3.5;B:2-2.5	7-8
425/65R22.5	A:3-3.5;B:2-2.5	10-12
445/65R22.5	A:3-3.5;B:2-2.5	10-12

ADC53

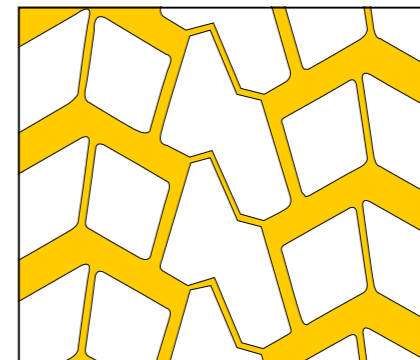

A B

Size	Depth (mm)	Width (mm)
11R22.5	2.5	A:10-12;B:5-7
12R22.5	2.5	A:10-12;B:5-7
13R22.5	2.5	A:10-12;B:5-7
315/80R22.5	2-2.5	A:10-12;B:5-7
12.00R24	2.5	A:10-12;B:5-7

ADL67

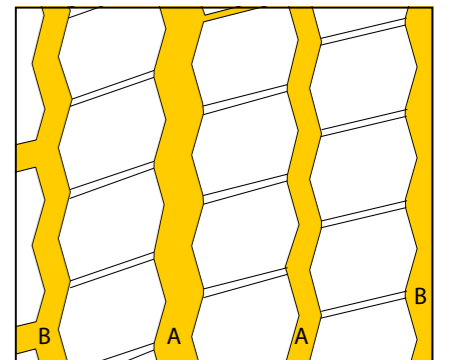

B A A B

Size	Depth (mm)	Width (mm)
295/60R22.5	A:2.5-3;B:2-2.5	A:10-12;B:5-7
295/80R22.5	A:3-3.5;B:2-2.5	A:10-12;B:5-7
315/60R22.5	A:2.5-3;B:2-2.5	A:10-12;B:5-7
315/70R22.5	A:3-3.5;B:2-2.5	A:10-12;B:5-7
315/80R22.5	A:3-3.5;B:2-2.5	A:10-12;B:5-7

NEO SERIES

WITH 100% WARRANTY!

NEO ALLROADS



NEO FUEL



NEO WINTER



The Aeolus NEO series - now with 100% guarantee! For a period of 2 years! High quality tyres with an impressively low price per kilometre and minimal wear. They are also in keeping with strict requirements in the transport sector.

All our tyres are produced under license from, and with the know-how of, Pirelli. From casing structure to rubber compound! The NEO Series offers you top quality at a competitive price. The tyres can be retreaded and the casing is ideal

for tread renewal. We are clearly convinced by the quality of our tyres. So convinced that our tyres come with a two-year guarantee. So dare us by trying our NEO series.

Aeolus. **No matter what.**



The NEO series are manufactured under a patent and know how license from Pirelli Tyre

For further information and the conditions, visit aeolus-tyres.com/warranty

AEOLUS
NO MATTER WHAT.

AEOLUS
NO MATTER WHAT

AEOLUS-TYRES.COM

AEOLUS
NO MATTER WHAT